

IMPULSE LOADING WITH AN ELECTRICALLY EXPLODED ETCHED COPPER MESH†

MICHAEL J. FORRESTAL, MATHIAS J. SAGARTZ and WILLIAM K. TUCKER
Simulation Technology Department, Sandia Laboratories, Albuquerque,
NM 87185, U.S.A.

(Received 27 March 1979; in revised form 7 September 1979)

Abstract—An impulse simulation technique for radiation-induced material blowoff on layers internal to reentry body shell structures was explored. Loading is provided by electrically exploding etched copper mesh patterns with a current from a capacitor discharge. Impulse intensities between 150 and 600 Pa·s (1500 and 6000 taps) were produced on an elastic pressure bar which was separated from the mesh by air gaps of 1.27 and 2.54 mm (0.050 and 0.100 in.). This loading technique is relatively easy to use, complements existing methods and should be applicable to many other problems.

INTRODUCTION

Many transient loading techniques which simulate surface loads on shell structures have been developed. Lindberg [1, 2] describes several explosive loading techniques developed at SRI International which load reentry vehicles and related structural models. In [1, 2] methods for producing loads with durations ranging from several microseconds to a few milliseconds are described. Other loading techniques devised to simulate impulse loads produced by radiation-induced material blowoff include magnetically driven flyer plates [3], magnetic pressure pulses [4], and light-initiated explosives [5].

The blowoff simulation techniques load the exterior surfaces of shell structures with nearly simultaneous, short duration pressure pulses. However, there is also the possibility that some material blowoff could occur on layers internal to these shell structures, and this loading is called tamped impulse. For this case, the material blowoff products are confined in a gap and are not allowed to expand freely. In [6], the possibility of simulating tamped impulse by exploding an etched copper mesh pattern with current from a capacitor discharge was explored. This preliminary study indicated that a practical range of impulse intensities could be produced on a simulated shell structure which was separated from the mesh by a 1.27 mm (0.05 in.) air gap. The present paper extends the information in [6] in that pressure-time pulses from the exploded mesh are measured with a strain-gaged, elastic pressure bar for 1.27 and 2.54 mm (0.05 and 0.10 in.) air gaps.

PRESSURE BAR EXPERIMENTS

The copper mesh pattern shown in Fig. 1 is a 18 μ m (0.7 mil) copper foil bonded to Mylar and chemically etched by the techniques used to manufacture printed circuits. The mesh is connected to a capacitor (BICC-ES108 with 27.5 μ F) and the individual bridgewires are electrically exploded by the discharge current.

The experimental apparatus used to measure impulse and pressure-time from the exploded mesh is shown in Fig. 2. A 76 by 152 mm (3.0 by 6.0 in.) rectangular mesh pattern is connected to the capacitor bank and exploded by the discharge current. Confinement of the gases generated by the exploded mesh is provided by a 50.8 mm (2.0 in.) thick, rectangular phenolic plate which is separated from the plane of the mesh by 1.27 or 2.54 mm (0.050 or 0.100 in.) air gaps. A 12.7 mm (0.50 in.) diameter, aluminum pressure bar is inserted into a hole in the rectangular phenolic plate and the loaded end of the pressure bar is butted against a 0.127 mm (0.005 in.) sheet of Mylar which is glued to the back face of the phenolic plate. This thin Mylar sheet provides the specified pressure bar-mesh air gaps and electrically insulates the strain-gaged pressure bar.

†This work was supported by the U.S. Department of Energy and the Defense Nuclear Agency under Subtask Code N99QAXX388 and Work Unit 47.

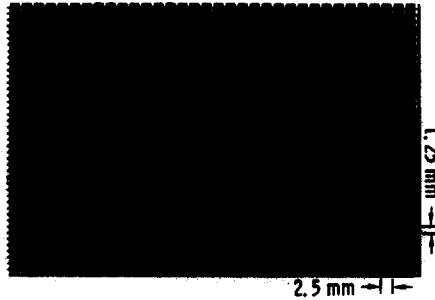

Fig. 1. Mesh pattern. The small connecting black lines are the bridgewires.

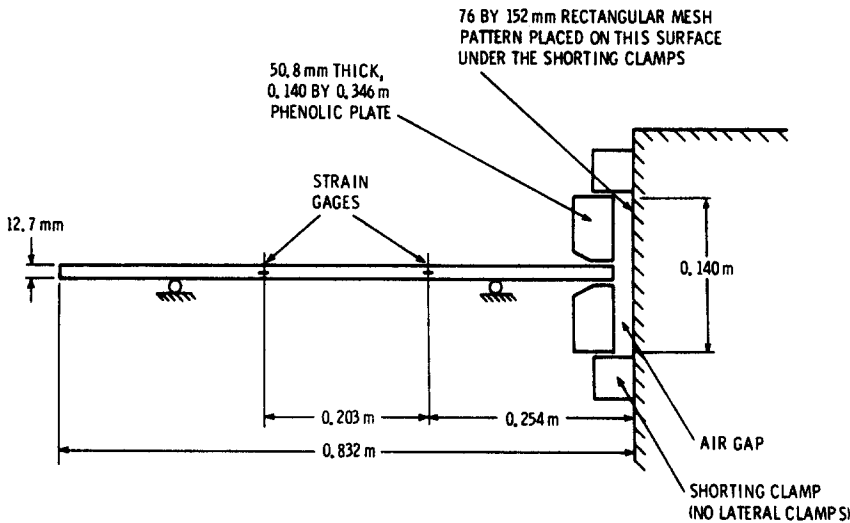

Fig. 2. Setup for pressure bar experiments.

Displacement at the free end of the bar is measured with a displacement gage (Kaman Measuring Systems Model KD-2300-2S) and recorded with a Tektronix Type 556 oscilloscope. Strain-time is measured with semiconductor strain gages (Kulite Type M(12)D-GP350-500) located at 0.254 m (10.0 in.) and 0.457 m (18.0 in.) from the loaded end. Strain data is recorded with a Nicolet Model 204 digital oscilloscope and plotted with the aid of a Tektronix 4051 computer.

As discussed in [7, 8] the axial displacement u at the end of an elastic bar from a short duration pressure pulse is a staircase-type response produced by the repeated reflections of the longitudinal pressure pulse. A typical displacement-time measurement at the end of the bar is shown in Fig. 3(a). Two impulse values are obtained from the displacement data. First, the rigid body velocity V of the bar is obtained from the slope of the line shown in Fig. 3(b). Momentum per unit bar area I is given by

$$I = MV/A \quad (1)$$

where A is the bar cross sectional area and M (0.300 kg) is the total rod mass. Another impulse value is obtained from the formula

$$I = \rho cd/2, \quad c^2 = E/\rho \quad (2)$$

which is derived in [8, 9]. In eqn (2) ρ is the density, c is the bar velocity, E is Young's modulus and d is the displacement magnitude shown in Fig. 3(b).

As previously mentioned, strain-time is measured at two axial locations and typical traces from one experiment are shown in Fig. 4. For all experiments the two traces were nearly

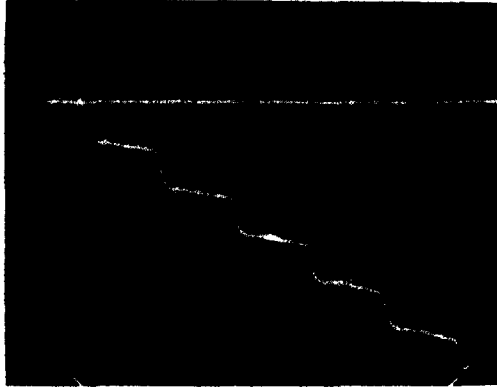

Fig. 3(a). Displacement-time for 2.54 mm (0.100 in.) air gap and 14 kV; 0.050 mm/Major div., 0.20 ms/major div.

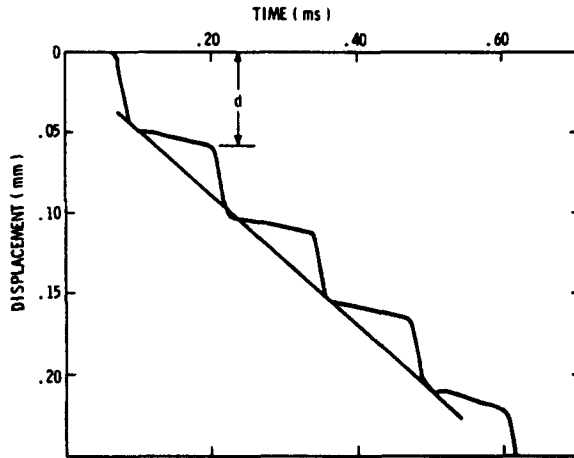

Fig. 3(b). Displacement-time and the straight line used to calculate rigid body velocity for 2.54 mm (0.100 in.) air gap and 14 kV.

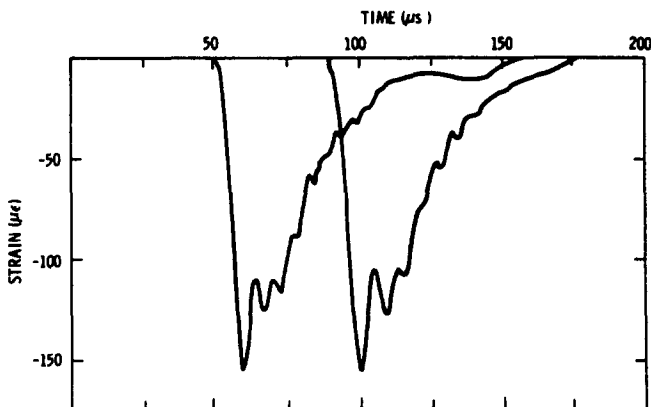

Fig. 4. Strain-time at $x = 0.254$ m and 0.457 m (10.0 and 18.0 in.) for 2.54 mm (0.100 in.) air gap and 14.0 kV.

identical in shape and only the trace closer to the loaded end of the bar was used for impulse or pressure diagnostics. The literature [9, 10] is rich with analytical solutions and experimental data which address the dispersion of elastic stress pulses which distort pressure bar measurements. However, for this application a reasonably accurate pressure-time measurement for pressures generation from the electrically exploded mesh pattern can be obtained from strain-time measurements. Using Hooke's law and assuming a one-dimensional stress condition in the rod, pressure-time is

$$p(t) = -E\epsilon(t) \quad (3)$$

where ϵ is measured positive in tension. A typical strain trace is shown in Fig. 4 and the additional strain data are presented in [11]. From the work presented in [9, 10], three comments on the pressure response data can be made: (1) the high frequency, low amplitude component of response riding on the main pulse with period 7–8 μs comes from the dispersion of the stress pulse and is not related to the pressure from the exploded mesh, (2) the rise times of the strain pulses are somewhat longer than the rise times of the pressure pulses from the exploded mesh, and (3) the longitudinal surface strains are less than the average strains over the cross section (see Fig. 21 of [9]). Impulse values can also be obtained from the integral of the strain-time traces and for this diagnostic

$$I = -E \int_0^{t^*} \epsilon(t) dt \quad (4)$$

where t^* is the time when the strain magnitude returns to zero.

RESULTS AND DISCUSSION

A summary of the experimental data for two air gaps between the copper mesh and the pressure bar is given in Tables 1 and 2. The second column gives the charge voltage for the 27.5 μF capacitor bank; the next three columns give the impulse magnitudes from the three diagnostics; and the last column gives the peak value of the pressure pulse. These data show

Table 1. Data for the 1.27 mm (0.050 in.) air gap experiments

Test Number	Charge Voltage	MV/A	pcd/2	$E \int_0^{t^*} \epsilon dt$	Peak Pressure
	kV	Pa·s	Pa·s	Pa·s	MPa
1	7.2	150	130	132	1.79
2	8.2	218	204	190	4.14
3	10.2	386	386	359	7.93
4	12.2	487	462	400	11.72
5	14.0	589	588	545	18.62

Table 2. Data for the 2.54 mm (0.100 in.) air gap experiments

Test Number	Charge Voltage	MV/A	pcd/2	$E \int_0^{t^*} \epsilon dt$	Peak Pressure
	kV	Pa·s	Pa·s	Pa·s	MPa
1	8.2	149	140	131	2.34
2	11.2	273	288	223	6.55
3	14.0	387	390	343	10.89
4	17.0	484	498	415	16.55

that a practical range of peak pressures and impulse loads can be obtained by varying the charge voltage of the capacitor bank. As previously mentioned, surface strains are less than average strains over the bar cross section and this is consistent with the lower values of impulse from the strain integral diagnostic reported in Tables 1 and 2. It should also be pointed out that the rise times, times at peak strain, and pulse duration are nearly the same for all experiments. Only the peak pressure is affected by changing the charge voltage and increasing the air gap simply lowers the peak pressure and impulse without changing the overall pulse shape.

In summary, pressure-time and impulse for the copper mesh pattern and experimental arrangement shown in Figs. 1 and 2 were measured. Data were obtained for two air gaps and a wide range of charge voltages for the $27.5\mu\text{F}$ capacitor bank. These experiments were designed to simulate the tamped impulse effect; however, the loading technique is relatively easy to use and should be applicable to a wide range of problems in structural mechanics.

Acknowledgement—The authors thank E. E. Jones for performing the experiments.

REFERENCES

1. H. E. Lindberg and R. D. Firth, Simulation of transient surface loads by explosive blast waves. Stanford Research Institute, Menlo Park, California, *Tech. Rep. No. AFWL-TR-66-163*, Vol. II (May 1967).
2. H. E. Lindberg and G. E. Sliter, Response of reentry-vehicle-type shells to transient surface pressures. Stanford Research Institute, Menlo Park, California, *Tech. Rep. No. AFWL-TR-68-56* (June 1969).
3. M. J. Forrestal, W. K. Tucher and W. A. Von Riesenmann, Impulse loading of finite cylindrical shells. *AIAA J.* 13 1396–1398 (Oct. 1975).
4. M. J. Forrestal and D. K. Overmier, An experiment on an impulse loaded elastic ring. *AIAA J.* 12, 722–724 (May 1974).
5. R. A. Benham and F. H. Mathews, X-Ray simulation and light-initiated explosive. *The Shock and Vibration Bulletin*, 45, 21–22 (Oct. 1974).
6. B. W. Duggin, M. J. Forrestal and R. I. Butler, Impulse from an electrically exploded etched copper mesh. *AIAA J.* Vol. 6, No. 8, August 1978, pp. 856–857.
7. H. Kolsky, *Stress Waves in Solids*, p. 91. Dover Publications, New York (1952).
8. H. Kolsky, The propagation of stress pulses in viscoelastic solids. *Phil. Mag. Series 8* 1, 693 (Aug. 1956).
9. R. M. Davies, A critical study of the Hopkinson pressure bar. *Phil. Trans. Soc. London, Series A*, 240, 375–457 (1948).
10. O. E. Jones and F. R. Norwood, Axially symmetric cross-sectional strain and stress distributions in suddenly loaded cylindrical elastic bars. *J. Appl. Mech.* 34, 718–724 (Sept. 1967).
11. M. J. Forrestal, M. J. Sagartz and W. K. Tucker, Tamped impulse simulation with an electrically exploded etched copper mesh. Sandia Laboratories, Albuquerque, N.M., SAND79-0132 (Feb. 1979).